

R15IT3S-67C3(HB)

15" Intel® Core™ i5-1135G7 G-WIN Full IP67 Panel PC



KEY FEATURES

- 11th Generation (Tiger Lake) Intel® Core™ i5-1135G7 2.4GHz (turbo to 4.2GHz)
- High Quality 15" Panel, 1024 x 768 resolution, 300 nits (Optional for 1000 nits)
- Dust/ Water proof design with VESA mount Full IP67 Panel PC
- Aluminum Die-Casting Housing with Anti-Corrosion Treatments
- Build in ambient Light sensor, Full IP67 Panel PC
- Wide Range 9 to 36V DC Input with isolation. Optional for Ignition On/Off delay
- Optional 6-60V DC Input, and Optional for Ignition On/Off delay
- 5 Wire Resistive Touch / Anti-Reflective Protection Glass (Optional)
- Optional HB/Sunlight Readable up to 1000 nits



SPECIFICATIONS

System Specification			
WLAN	Support (Optional)	BT	Support (Optional)
Processor	Intel Core i5-1135G7 2.4GHz (up to 4.2GHz) Intel Core i5-1145G7 2.6GHz (up to 4.4GHz) (Optional)	Memory	1 x SO-DIMM, DDR4 3200 MHz, 4GB 8GB (Optional) 16GB (Optional) 32GB (Optional)
Storage	1 x M.2 M-Key 2242 SATA SSD or 1 x M.2 M-Key 2280 NVMe SSD 128GB 256GB (Optional) 512GB (Optional) 1TB(for NVMe) (Optional) 2TB(for NVMe) (Optional) 4TB(for NVMe) (Optional)	Ethernet controller	2 x Intel® Ethernet Controller
Security	TPM 2.0	Operating System	Windows 11 IoT Enterprise SAC (64 bit) (Optional) Windows 10 IoT Enterprise (64 bit) (Optional) Linux Ubuntu 22.04 (Optional)
Display			
Resolution	1024x768	Size	15 inches
Contrast Ratio	2000:1	Panel Brightness	300 nits
View Angles	88,88,88,88	Active Area	304.1x228.1 mm
Touch / Glass	Resistive Touch Screen Bonding With Panel Protection Glass Without touch function (Optional)	Optional function	High brightness Panel for sunlight readable (Optional)
Mechanical			
Dimension	398 x 308 x 58 mm	Mounting	VESA Mount Yoke Mount
Enclosure	Aluminum Housing	Cooling System	Fanless design
Environment			
Operating Humidity	10% to 90% RH, Non-Condensing	Operating Temperature	-10°C to 55°C -40°C to 70°C (with intelligent heater)
Storage Temperature	-30°C to 70°C	Shock	MIL-STD-810G Method 516.6 Procedure I (Optional)
Vibration	MIL-STD-810G Method 514.6 Procedure I	IP rating	IP67

Certification			
Certification	CE, FCC		
IO Ports			
Power Input	1 x M12 waterproof connector for 9~36V DC	USB Port	1 x M12 waterproof connector for 2 x USB2.0
Serial Port	1 x M12 waterproof connector for RS232	LAN	1 x waterproof Giga LAN RJ45 connector
Indicator	1 x LED Indicator for power 1 x LED Indicator for storage		
Control			
Button	1 x Power Button 1 x Reset Button 1 x Lock / Unlock front key function button 1 x Auto Dimming / Manually button 1 x Day / Night Mode button 1 x Brightness Up button 1 x Brightness Down button 1 x LED indicator brightness adjustment button 1 x Light sensor		
Accessory			
Accessory	External open wire Power cable with waterproof connector External USB cable with waterproof connector External COM cable with waterproof connector External LAN cable with waterproof connector Waterproof caps RJ45 female-female converter VESA screws	Optional Accessory	Yoke mount stand (Optional) 100~240V AC to DC Adapter with power cord (Optional)

DIMENSIONS UNIT:MM

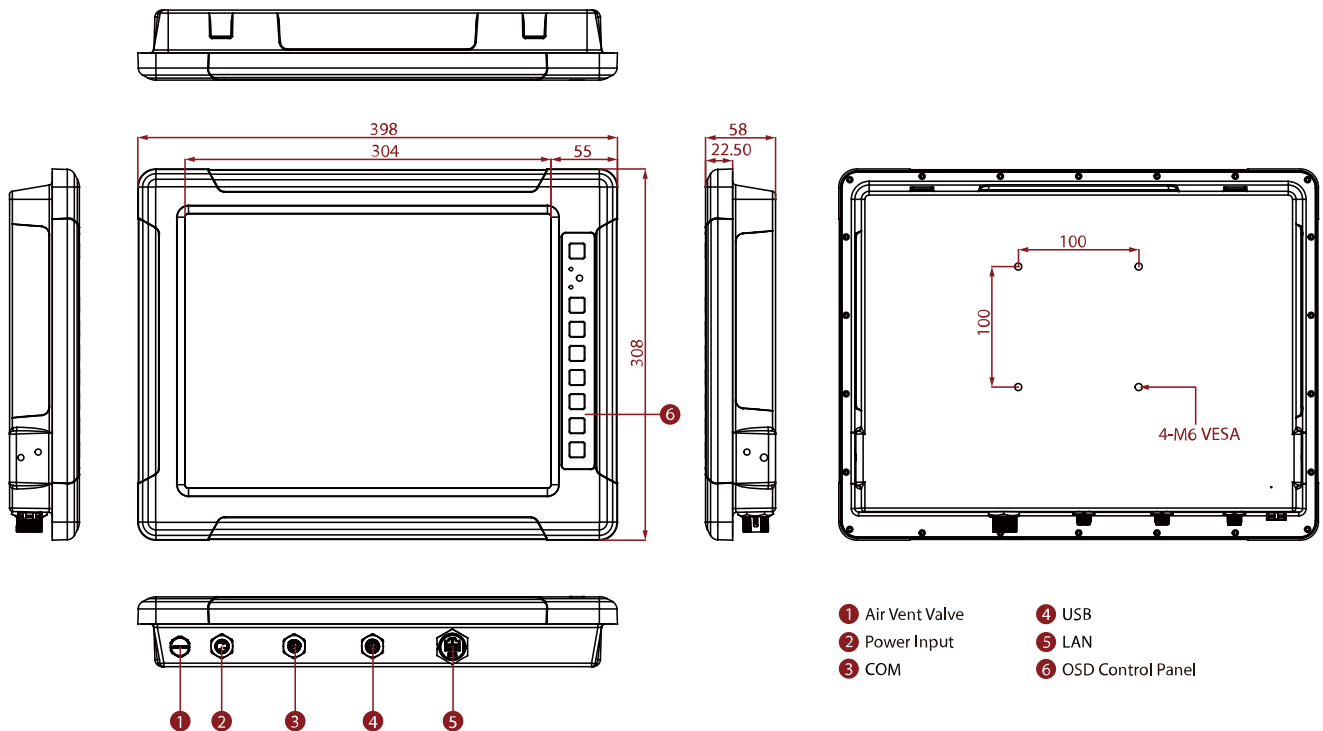

NOTE

1. This is a simplified drawing and some components are not marked in detail.
2. Weight of the device varies by configuration.
3. Please contact our sales representative if you need further product information.
4. All specifications are subject to change without prior notice.
5. The product shown in this datasheet is a standard model. For diagrams that contain customized or optional I/O, please contact the Winmate Sales Team for more information.

