

R10L100-VMT2

10.4" G-WIN VM Series Display



KEY FEATURES

- High Quality 10.4" SVGA Panel, 1024 x 768 resolution
- Front IP65 Dust/water resistant Protection (Except I/O parts)
- Aluminum Housing with Anti-Corrosion Treatments
- Anti-Shock and Vibration
- Standard according to MIL-STD-810F & IEC60068-2-27
- 5 Wire Resistive Touchscreen
- Anti-Reflection Protection Glass(Optional)
- Wide Range 9 to 36V DC Input Acceptable



SPECIFICATIONS

Display			
Resolution	1024x768	Size	10.4 inches
Contrast Ratio	1000:1	Panel Brightness	350 nits
Display Color	16.2M Colors	View Angles	88,88,88,88
Touch / Glass	Resistive Touch Screen Protection Glass w/o Touch Function (Optional)		
Environment			
Operating Humidity	10% to 95% (Non-Condensing)	Operating Temperature	-10°C~55°C
Storage Temperature	-30°C~70°C	Shock	Operating:30g for 18ms
Vibration	Operating: 1.60/1.96/2.18 g rms for XYZ / 5-500Hz		
Certification			
Certification	CE, FCC		
IO Ports			
USB Port	1 x USB for Touch Screen (Optional)	Serial Port	1 x RS232 for Touch Screen (Optional)
Video	1 x VGA 1 x S-Video (Optional) 1 x Composite (Optional)		
Mechanical			
Dimension	315.9 x 250.9 x 67 mm	Mounting	VESA Mount
Enclosure	Metal Housing with Aluminum Bezel	Cooling System	Fanless Design
Accessory			
Accessory	User Manual(Hardcopy) Touch Driver CD 3 Pin Terminal Block AC Adapter Power Cord Mounting Bracket		
Power			
Power Rating	9V~36V DC In Terminal Block		
Control			

DIMENSIONS UNIT:MM

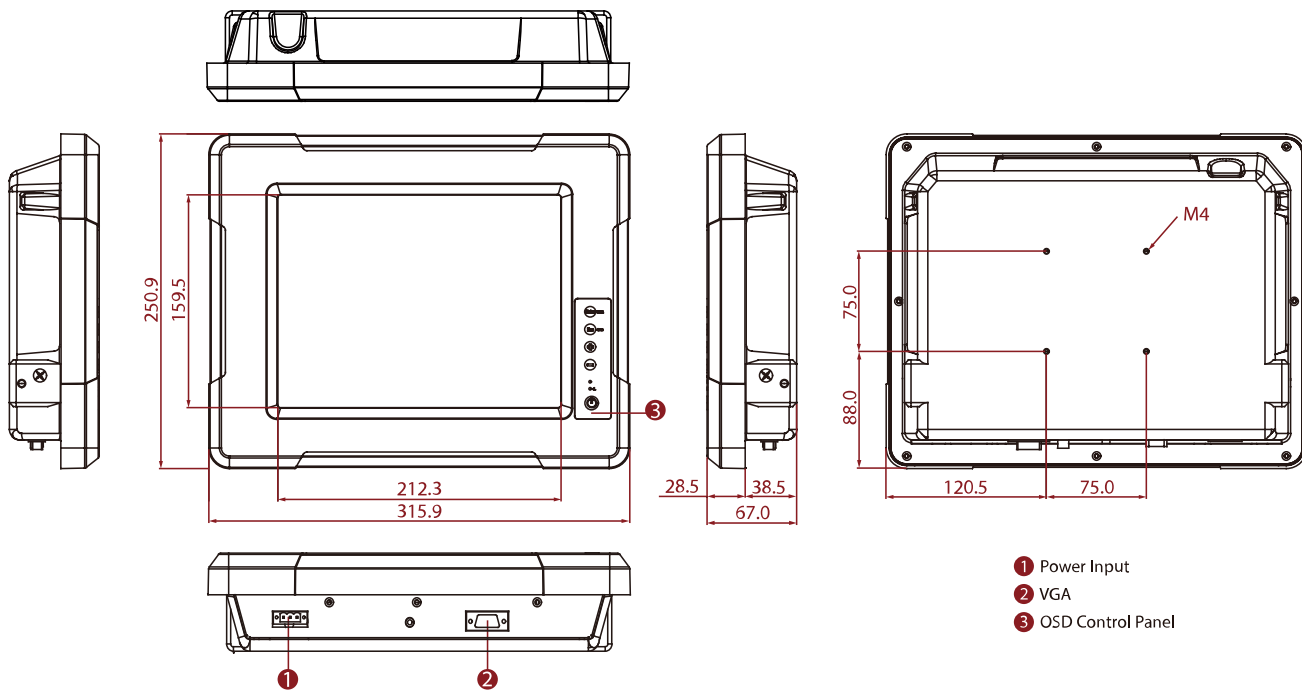

NOTE

1. This is a simplified drawing and some components are not marked in detail.
2. The product shown in this datasheet is a standard model. For diagrams that contain customized or optional I/O, please contact the Winmate Sales Team for more information.
3. All specifications are subject to change without prior notice.