

FM12E-V

12.1" Windows Forklift Computers with Intel® Elkhart lake x6425E



KEY FEATURES

- Intel® Elkhart lake x6425E Processor, Windows forklift computers
- 12.1" 1024 x 768 Panel with PCAP touch screen
- IP65 waterproof and dustproof
- Wide power input 9-36V DC with ignition
- Wide range operating temperature
- Support VESA Mount



SPECIFICATIONS

Display			
Type	Projected Capacitive Multi Touch	Touch Mode	With Stylus Support With Gloves Support
Resolution	1024x768	Size	12.1 inches
Contrast Ratio	1000:1	Panel Brightness	400 nits 800 nits(Optional)
View Angles	89,89,89,89		
System Specification			
Processor	Intel Elkhart Lake x6425E Processor , 2.0 GHz	Memory	4GB SODIMM DDR4-3200 8GB SODIMM DDR4-3200 (Optional)
Storage	128GB M.2 SSD 256GB M.2 SSD (Optional)	Security	TPM 2.0
Operating System	Windows 10 IoT Enterprise	WLAN	Support
BT	Support	WWAN	4G/LTE (Optional)
GNSS	GPS/GLONASS (Optional)	Sensors	G-Sensor, Light Sensor ,Temp Sensor
Camera			
Front Camera	2MP Camera		
Environment			
Operating Humidity	5% to 90% RH, Non-Condensing	Operating Temperature	-30°C to 50°C
Storage Temperature	-30°C to 60°C	Shock	MIL-STD-810H Method 516.8 Procedure I
Vibration	MIL-STD-810H Method 514.8 Procedure I	IP rating	IP65 Certified, Waterproof and Dustproof
Impact	Support EN62262 IK07 Rating	ESD	Compliant with EN 61000-4-2, enhanced ESD to ±12kV direct & ±15kV air
Certification			
Certification	CE, FCC, UL60950-1, EN60950-1, PTCRB, FCC (Electromagnetic Emissions), IC (ICES-003)		
Control			
Button	1 x Power Button, 5 x Function Button (Programmable Function Key Configured by Winset)		
IO Ports			

USB Port	1 x USB Type-C 1 x USB 2.0 Type-A	Serial Port	2 x RS232/422/485 (Default RS232)
SD Card Slot	1 x Micro SD Card Slot	SIM Card Slot	1 x Dual-Nano SIM Card Slot
LAN	1 x Gigabit LAN port	Indicator	4 x LED Indicator (WLAN, UPS battery, HDD, Heater)
DIDO	1 x DIDO (2XDI ; 2XDO) (Optional)	CANBUS	1 x CANBus (Optional)
Mechanical			
Dimension	306.6 x 225 x 56.6 mm	Weight	2.4kg
Mounting	RAM Mount/ VESA Mount	Cooling System	Fanless Design
Security Function			
SOTI MobiControl	SOTI MobiControl Compliance		
Accessory			
Accessory	5M Power Cable with Fuse Kit 0.15M Power Converter Cable DC Jack Power Cable 84W Adapter with power cable Quick Start Guide Stylus Kit + Screw	Optional Accessory	1.8M RS232 Cable 2M IP65 LAN Cable GPS & LTE 2M Combo Antenna(VM240) GPS & LTE 5M Combo Antenna (VM9C) GPS & LTE Combo Antenna (VM10S) GPS Antenna WWAN Antenna 2M Waterproof USB Type-A to A Cable Cable Clamp Kit COM Port + CANBus Cable COM Port + DIDO Cable
Power			
Battery	400mAh UPS Battery for 20 minutes backup (Optional)	Power Rating	9V~36V with ignition control

DIMENSIONS UNIT:MM

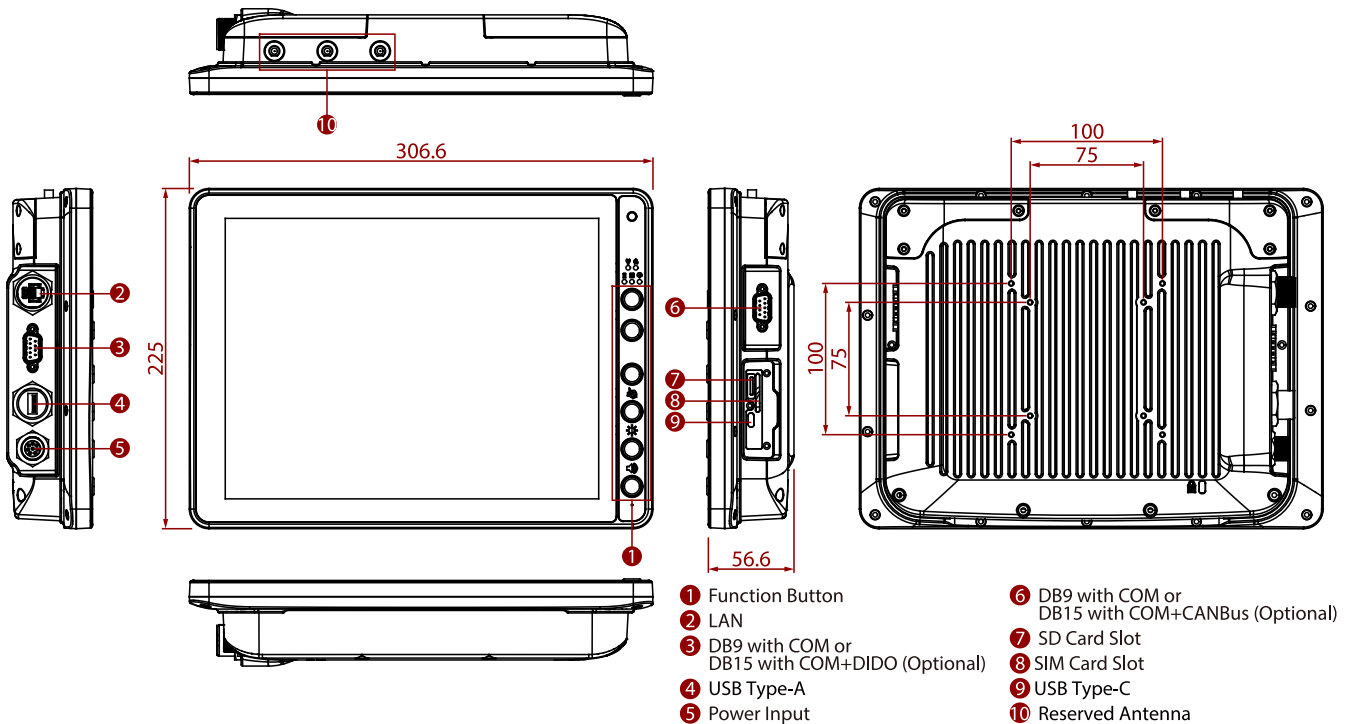

NOTE

1. Total usable memory will be less dependent upon actual system configuration.
2. SOTI is available upon request.
3. Length measurements do not include protrusions. Weight varies with options.
4. Measured at dimming LCD brightness. Varies depending on the usage conditions, or when an external device is attached.
5. Accessories may vary depending on your configuration.
6. This is a simplified drawing and some components are not marked in detail.
7. The product shown in this datasheet is a standard model. For diagrams that contain customized or optional I/O, please contact the Winmate Sales Team for more information.